

## Fenix TK65R Flashlight

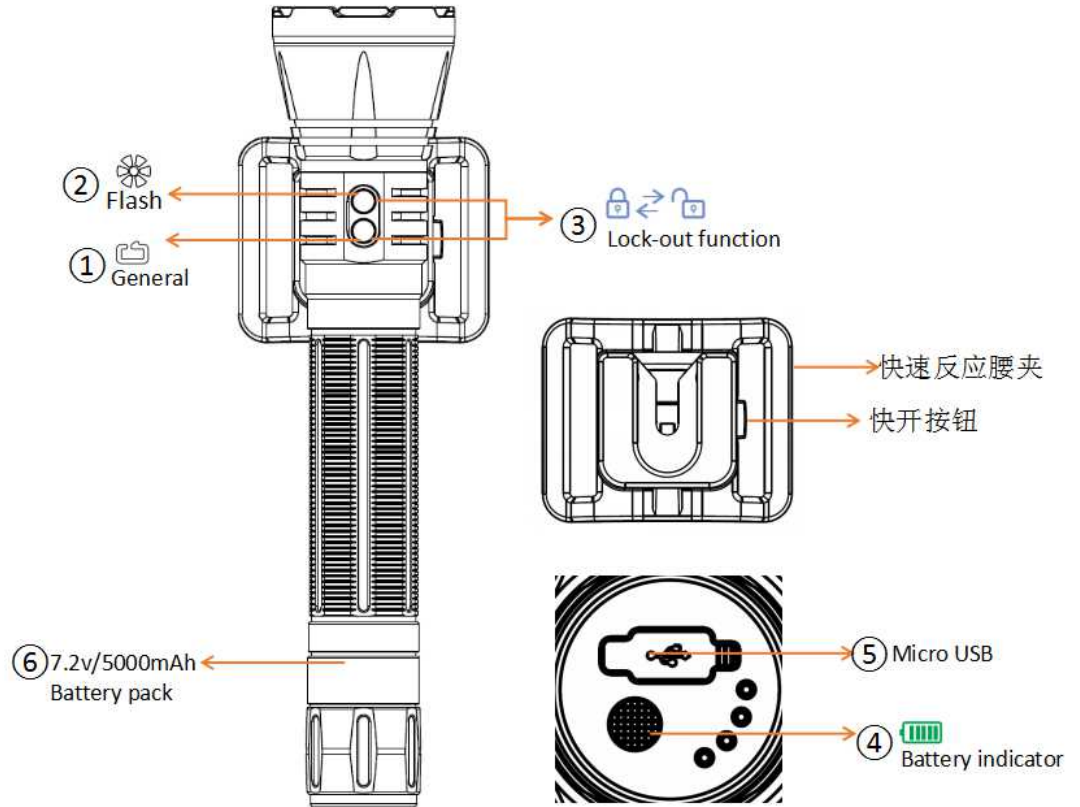

1. Catapult action belt clip

2. Quick-release button

### Technical Parameters

ANSI/PLATO	General Mode					Flash Mode	
	Turbo	High	Med	Low	Eco	Strobe	SOS
FL1							
<b>Output</b>	3,200 Lumens	1,000 Lumens	400 Lumens	150 Lumens	30 Lumens	3,200 Lumens	400 Lumens
<b>Runtime</b>	1h 45min	4h 55min	13h 10min	35h 45min	113h	/	/

<b>Distance</b>	375m	218m	138m	83m	37m	/	/
<b>Intensity</b>	35,155 cd	11,880 cd	4,760 cd	1,720 cd	340 cd	/	/
<b>Impact Resistance</b>	1m						
<b>Waterproof</b>	IP68, underwater 2m						

Note: The abovementioned parameters (lab-tested by Fenix using 7.2V/5000mAh Li-ion battery pack) may vary between flashlights, batteries and environments.

- Cree XHP70 LED with a lifespan of 50,000 hours
- Built-in 7.2V/5000mAh Li-ion battery pack
- Micro USB fast charging with fast charging adaptor
- Micro USB charging port with inner waterproofing design
- 270.5mm Length x 61.5mm Head diameter x 36.5mm Body diameter
- 418g (excluding battery and belt clip)
- Dedicated catapult action belt clip
- Digitally regulated output maintains constant brightness
- Featuring battery level indication and low-voltage warning function
- Intelligent overheat protection protects from high surface temperature
- Made of durable aircraft-grade aluminum; stainless steel strike bezel
- Premium type III hard-anodized anti-abrasive finish
- Toughened ultra-clear glass lens with an anti-reflective coating

Accessories:

7.2V/5000mAh Li-ion battery pack

Spare O-ring



Micro USB charging cable

USB adaptor

Catapult action belt clip

## Operation

### Switches

- ①  Master switch: controls on/off and output selection in General mode
- ②  Auxiliary switch: controls on/off and output selection in Flash mode

**ON:** With the light switched off, press and hold the Master switch for 0.5 seconds to enter General mode, press and hold the auxiliary switch for 0.5 seconds to enter Flash mode.

**OFF:** With the light switched on, press and hold either the master or auxiliary switch to turn off the light.

### Mode Selection

In General mode, single click the auxiliary switch to change to Flash mode.

In Flash mode, single click the master switch to change to General mode.

### Output selection

In General mode, single click the master switch to cycle through Eco→Low→Med→High→Turbo.

In Flash mode, single click the auxiliary switch to cycle through Strobe→SOS.

### ③ Lock-out Function

**Lock:** with the light unlocked, simultaneously press and hold the two switches for over 3 seconds. Light will switch off and 2 one-second blinks will indicate locked status.

**Unlock:** with the light locked, simultaneously press and hold the two switches for over 3 seconds. The light will be unlocked and activated on last used brightness.

In locked status, pressing any switch will activate 2 one-second blinks to indicate locked status.

### **Intelligent Memory Circuit**

The light memorizes the last selected brightness level on General mode. When turned on again the previously used brightness level will be recalled.

### **Intelligent Overheat Protection**

The light will accumulate a lot of heat when used on Turbo output level for extended periods. When a temperature of 65°C or above is reached, the light will automatically step down by a few lumens to reduce temperature. When the temperature is reduced, the output will gradually return to Turbo output level.

### **④ Battery Level Indication**

There are four LED's in the light tail. Single clicking the round switch on the tail will indicate remaining battery level for 3 seconds:

The more LED's light up, the higher the battery level.

Four LED's on: more than 80%;

Only one LED on: more than 20%

One LED flashing: less than 20%

### **Low-voltage Warning**

When the voltage level drops below the preset level, the flashlight is programmed to downshift to a lower brightness level until Eco output is reached. When this happens in Eco output mode, the flashlight blinks three times every five minutes to remind you to replace the battery. To ensure normal use, the flashlight will only turn off once the battery over-discharging protection activates.

### **⑤ Charging**

First plug the USB terminal of the charging cable into an electrical outlet, then connect the Micro USB terminal of the charging cable to the light. The LED indicators will flash in sequence while charging, and will turn to constant on when fully charged. The normal charging time is

approximately 4 hours.

Note:

1. Once charging is completed, be sure to close the anti-dust cover.
2. Recharge a stored light every four months to maintain optimum performance of the battery.

## ⑥ Battery Replacement

Unscrew the tail cap to insert the battery (no need to check the polarity), then screw the tail cap back on. Remove the insulation sheet before first use.

## Usage and Maintenance

- Disassembling the sealed head can cause damage to the light and will void the warranty.
- Long-term use can result in O-ring wear. To maintain a proper water seal, replace the ring with an approved spare.
- Periodic cleaning of the battery contacts improves the lamp's performance as dirty contacts may cause the lamp to flicker, shine intermittently or even fail to illuminate for the following reasons:

A: The batteries need replacing.

Solution: Replace batteries (Ensure batteries are inserted according to the manufacturer's specifications).

B: The threads, PCB board contact or other contacts are dirty.

Solution: Clean the contact points with a cotton swab soaked in rubbing alcohol.

If the above methods don't work, please contact your authorized distributor.

## Warning



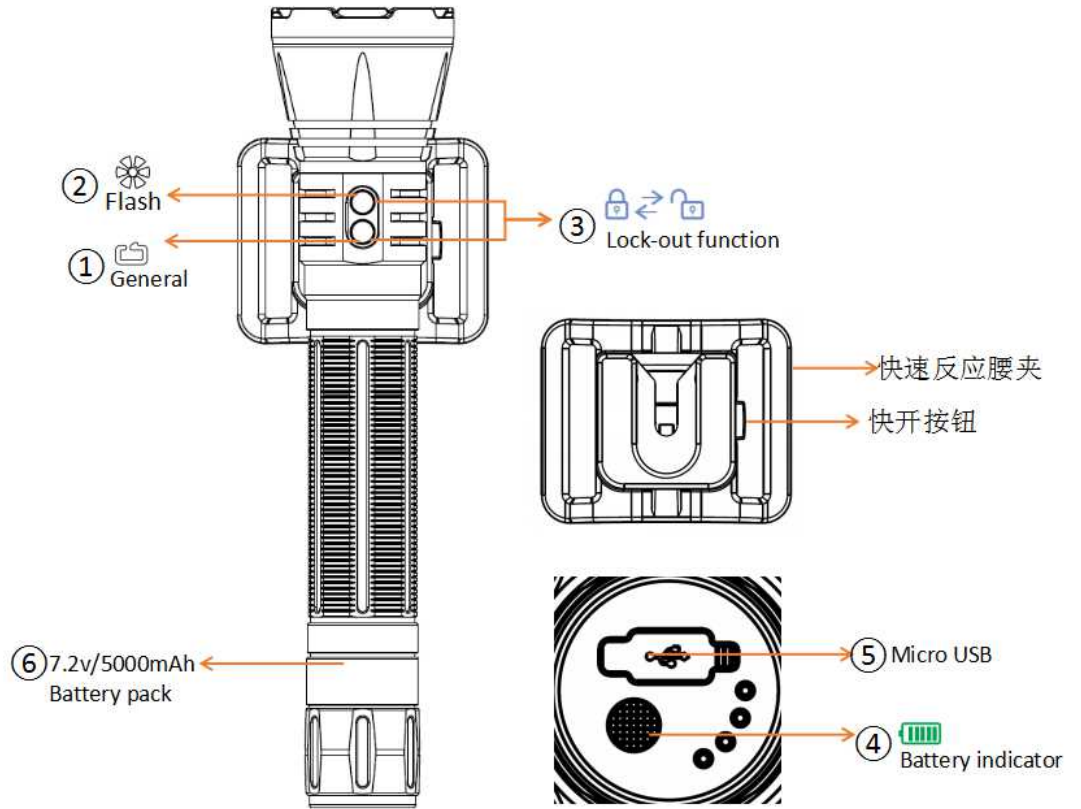

This flashlight is a high-intensity lighting device capable of causing eye damage to the user or others. Avoid shining the flashlight directly into anyone's eyes.

# Fenix TK65R 手电



## 技术参数

ANSI/PLATO	照明模式					闪烁模式	
	极亮档	高亮档	中亮档	低亮档	节能档	爆闪	SOS
FL1							
亮度	3200 流明	1000 流明	400 流明	150 流明	30 流明	3200 流明	400 流明

 续航时间	1 小时 45 分	4 小时 55 分	13 小时 10 分	35 小时 45 分	113 小时	/	/
 射程	375 米	218 米	138 米	83 米	37 米	/	/
 光强	35155 坎德拉	11880 坎德拉	4760 坎德拉	1720 坎德拉	340 坎德拉	/	/
 防跌落高度	1 米						
 防水等级	IP68, 水下 2 米						

注：上述参数只是一个近似值，是以内置的 7.2V/5000 mAh 锂离子电池包在实验室环境中测试所得，可能会随着手电、电池和使用环境的变化而发生变化。

#### 续航曲线图(参考续航曲线)

- ◎使用 Cree XHP70 LED，寿命 50000 小时
- ◎内置 7.2V/5000 mAh 锂离子电池包
- ◎Micro USB 快速充电，配置快充适配器
- ◎Micro USB 充电口采用更安全的内防水结构

◎270.5 毫米(长) X 61.5 毫米(筒头直径)X36.5 毫米 (筒身直径)

◎净重 418g(不含电池、快拆腰夹)

◎配置专业的快速反应腰夹

◎恒流电路，亮度恒定

◎具有电量显示和低压警示功能，

◎智能过热保护，防止外壳温度过高影响使用舒适度

◎采用航空铝材制造，配置不锈钢攻击头

◎表面进行了军规三级硬质阳极氧化的抗磨处理

◎使用双面增透膜钢化玻璃镜片

### 配件：

7.2V/5000 mAh 锂离子电池包

备用 O 圈

Micro USB 充电线、

USB 适配器

快速反应腰夹

### 操作说明

#### 按键定义

①



主开关（后）：主要负责照明模式的开关和档位切换

②



副开关（前）：主要负责闪烁模式的开关和档位切换

**开机：**关机状态下，长按主开关 0.5 秒进入照明模式，长按副开关 0.5 秒进入闪烁模式

**关机：**开机状态下，长按主开关或副开关 0.5 秒进行关机

**模式切换：**

照明模式下，单击副开关切换到闪烁模式

闪烁模式下，单击主开关切换到照明模式

### 档位切换：

照明模式下，单击主开关，可按极亮档→节能档→低亮档→中亮档→高亮档→循环的顺序调节亮度档位

闪烁模式下，单击副开关，可按爆闪→SOS→循环的顺序切换档位

### 锁键与解锁

③

未锁定状态下，同时按下主开关和副开关 3 秒以上，手电以低亮档闪烁 2 次后自动关机并进入锁定状态；再次同时按下主开关和副开关 3 秒以上，手电解除锁定状态并以记忆档位点亮。

锁定状态下，按下主开关或副开关，手电均会以低亮档闪烁 2 次然后熄灭，提示目前处于锁定状态。

### 智能记忆电路

手电会自动记忆照明模式的亮度档位，但不会记忆闪烁模式档位。每次打开照明模式时，手电都会以关闭前的亮度档位开始工作。

### 过热保护

由于本产品长时间工作在极亮档时，会积累大量热量，当温度达到 65℃或以上时，手电会启动过热保护功能，自动阶梯式降低亮度，当温度恢复且低于 65 度，则亮度会逐次上升，直到当前档位的最高亮度。

### 电量显示

④

TK65R 具有电量显示功能，手电尾部有四颗 LED 指示灯，单击手电尾部的圆形开关，即可以获得电池剩余电量信息，显示 3 秒自动熄灭，被点亮的 LED 颗数越多则表示剩余电量越多，四颗 LED 点亮表示电池剩余电量大于总容量的 80%，只有一颗 LED 点亮表示电池剩余电量大于总容量的 20%，当一颗 LED 闪烁时则表示电池剩余电量小于总容量的 20%

### 低电警示

如果手电检测到电池电压过低，会逐步的自动降低当前工作档位，直到降低到节能档为止；如果在节能档时电池电压过低，，则每 5 分钟闪 3 次提醒用户更换电池，同时为了保证用户的正常使用，手电不会主动关机，将一直持续工作至电池启动过放保护为止。

## ⑤ 充电说明

充电时，先将充电线的 USB 端口插入充电适配器，揭开手电尾部的防尘帽，将充电线的 Micro USB 端口插入手电的充电接口，此时手电筒尾部的四颗指示灯将循环闪烁，表示此时已经开始充电；四颗指示灯均持续点亮时，充电结束。标配充电器的充满时间约 4 小时。

### 注意：

- 1、充电结束后请将防尘帽盖回按紧，以免灰尘或杂物进入，但不影响防水性能。
- 2、由于电池会缓慢的自放电，所以我们建议用户长时间不使用手电时，仍然每四个月进行一次充电操作，以免电池受损。

## ⑥ 电池更换

旋开尾部装入标称电池（无需校对正负极），旋紧尾部即可工作（首次使用请先取出电池绝缘片）。

## 使用与维护

◎请勿拆卸手电头部密封部件，否则将会导致保修失效并可能损坏手电。

◎长期使用后，手电的 O 圈可能受损。如果发现了这种情况，请您更换 O 圈以维持手电的防水性能。

◎请经常清洁手电的导电接触面以保证手电的正常工作，特别是当手电出现异常的闪烁或者无法点亮的时候。以下是几个可能导致手电出现异常的闪烁或者无法点亮的原因：

一： 电池电量不足

解决方案： 及时充电

二： 尾部导电接触面或其他接触面/接触点被弄脏了。

解决方案： 用酒精棉签清洁导电接触面。

如果上述方法无效，请联系经销商并按照售后服务条款保修。

需要制作手电与快拆手电腰夹使用指引图，（根据排版要求提供）

重量，含电池 640.6g，含腰夹 707g

中心发光角 度	11°
泛光发光角 度	61°

工作电压范围： 6V-8.4V

极限工作电压范围： 5.5V -10V

最大功率 33W

